

INMBSDAL0640500

DALI to Modbus TCP Server Gateway

Order Code: INMBSDAL0640500

Installation Sheet version 1.3

HMS Industrial Networks S.L.U ©

SAFETY INSTRUCTIONS

WARNING

Follow carefully this safety and installation instructions. Improper work may lead to serious harmful for your health and also may damage seriously the Intesis gateway and/or any other equipment connected to it.

The Intesis gateway must be installed by accredited electrician or similar technical personnel, following all the safety instructions given here and in accordance always with the country legislation for installation of electric equipment.

The Intesis gateway cannot be installed outdoors or exposed to direct solar radiation, water, high relative humidity or dust.

The Intesis gateway must only be installed in a restricted access location.

In case of wall mount, fix firmly the Intesis gateway on a not vibrating surface following the instructions next.

In case of DIN rail mount fix the Intesis device properly to the DIN rail following the instructions below.

Mounting on DIN rail inside a metallic cabinet properly connected to earth is recommended.

Disconnect always power of any wires before manipulating and connecting them to the Intesis device.

A power supply with an NEC Class 2 or Limited Power Source (LPS) and SELV rated is to be used.

Respect always the expected polarity of power and communication cables when connecting them to the Intesis gateway.

Supply always a correct voltage to power the Intesis gateway, see details of voltage range admitted by the device in the technical characteristics below.

CAUTION: The device is to be connected only to networks without routing to the outside plant, all communication ports are considered for indoor only.

This device was designed for installation in an enclosure. To avoid electrostatic discharge to the unit in environments with static levels above 4 kV, precautions should be taken when the device is mounted outside an enclosure. When working in an enclosure (ex. making adjustments, setting switches etc.) typical anti-static precautions should be observed before touching the unit.

Safety instructions in other languages can be found at:

<https://intesis.com/docs/manuals/v6-safety>

CONFIGURATION

Use the **Configuration Tool** to configure the gateway.

See instructions to download and install the latest version at: <https://www.intesis.com/products/intesis-maps#download>

Use the Ethernet connection for communication between the gateway and the configuration tool. See CONNECTIONS below and follow instructions of user's manual for more details.

Owner's Record

The serial number is located at the rear of the gateway. Record this information in the space provided below. Refer to it whenever you contact upon your gateway dealer or support team regarding this product.

Serial No. _____

INSTALLATION

Follow instructions next to properly install the gateway.

Disconnect from mains the power supply before connecting it to the Intesis device.

Disconnect power of any bus or communication cable before connecting it to the Intesis gateway.

Mount the Intesis device on the wall or DIN rail following the instruction given below, respecting the safety instructions given above.

Connect a NEC Class 2 or Limited Power Source (LPS) and SELV rated power supply to the Intesis device, respect the polarity if DC power or Line and Neutral if AC power. Apply always a voltage within the range admitted by the Intesis device and of enough power (see technical characteristics).

Circuit-breaker must be used before the power supply. Rating 250V-6A.

Connect the communication cables to the Intesis gateway, see details on the user's manual.

Power the Intesis gateway and the rest of devices connected to it.

Wall Mount

1. Separate the fixing clips in the bottom of the box, pushing them to the outside until hear the "click" which indicates that now the clips are in position for wall mount, see in the figure below.
2. Use the holes of the clips to fix the box in the wall using screws. Use the template below for the wall wholes.

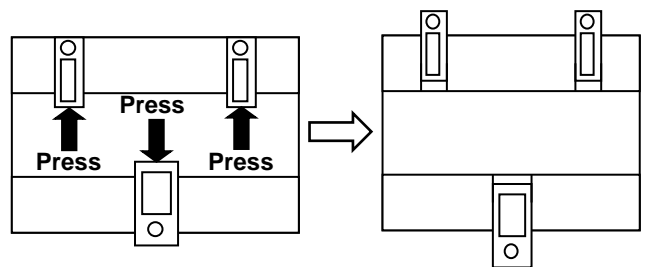

Clips in their original position (for DIN rail mount)

Clips in position for wall mount

DIN Rail Mount

With the clips of the box in their original position, insert first the box in the upper part of the DIN rail and later insert the box in the down part of the rail, using a small screwdriver and following the steps in the figure below.

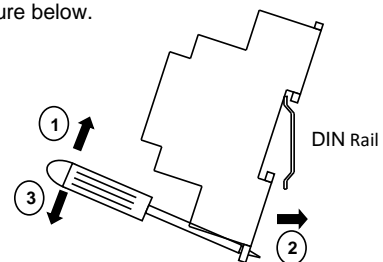

CONNECTIONS

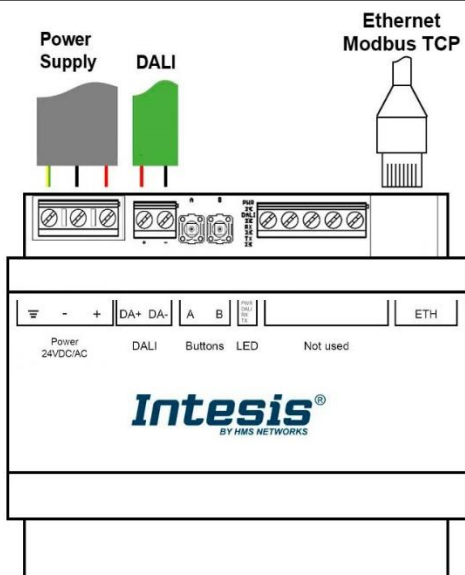

Power Supply

Must use NEC Class 2 or Limited Power Source (LPS) and SELV rated power supply. Respect polarity applied of terminals (+) and (-). Be sure the voltage applied is within the range admitted (check table below). The power supply can be connected to earth but only through the negative terminal, never through the positive terminal.

Ethernet / Modbus TCP / Console (UDP & TCP)

Connect the cable coming from the IP network to the connector ETH of the gateway. Use an Ethernet CAT5 cable. If communicating through the LAN of the building, contact the network administrator and make sure traffic on the port used is allowed through all the LAN path (check the gateway user manual for more information). With factory settings, after powering up the gateway, DHCP will be enabled for 30 seconds. After that time, if no IP is provided by a DHCP server, the default IP 192.168.100.246 will be set.

DALI

Connect the DALI bus to connectors DA+, DA- of gateway's DALI port. The Intesis gateway provides 16VDC DALI voltage to the bus. Please, respect polarity when other DALI power supplies are connected in the same DALI bus.

ELECTRICAL & MECHANICAL FEATURES

Enclosure	Plastic, type PC (UL 94 V-0) Net dimensions (dxwxh): 88x106x56 mm Recommended space for installation (dxwxh): 130x115x100mm Color: Light Grey. RAL 7035	Push Button	Button A: Check the user manual Button B: Check the user manual
Mounting	Wall. DIN rail EN60715 TH35.	Operation Temperature	0°C to +50°C
Terminal Wiring (for power supply and low-voltage signals)	Per terminal: solid wires or stranded wires (twisted or with ferrule) 1 core: 0.5mm ² ... 2.5mm ² 2 cores: 0.5mm ² ... 1.5mm ² 3 cores: not permitted	Operational Humidity	5 to 95%, no condensation
Power	1 x Plug-in screw terminal block (3 poles) Positive, Negative, Earth 24VDC/AC +/-10% 6W(250mA)	Protection	IP20 (IEC60529)
Ethernet	1 x Ethernet 10/100 Mbps RJ45 2 x Ethernet LED: port link and activity	LED Indicators	6 x On board LED indicators 1 x Power LED (Green) 1 x DALI (Yellow) 1 x RX (Green) 1 x TX (Yellow) 1 x Button A indicator 1 x Button B indicator
DALI	1 x DALI port (Plug-in screw terminal block 2 poles) 1500VDC isolation from other communication ports DALI guaranteed power: 230mA DALI Maximum Power: 250mA Voltage rating: 16VDC		

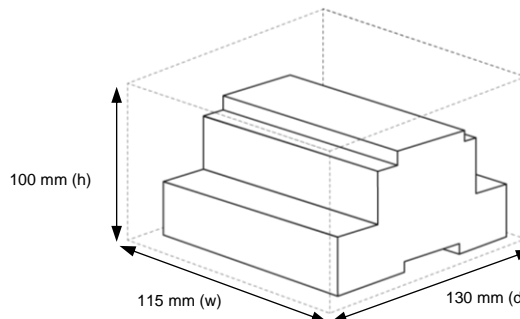

This marking on the product, accessories, packaging or literature (manual) indicates that the product contains electronic parts and they must be properly disposed of by following the instructions at <https://intesis.com/weee-regulation>