

# LoRaWAN® CT Clamp: Three Channel

Monitor granular energy use at a circuit, zone or machine level, in real time.

Our wireless current sensors (CT) simply clip around three individual cables, measuring the alternating current (AC) and the wireless transmitter attaches outside the panel for reliable wireless data transmission. The small, energy harvesting devices use ultra-low power wireless and battery-less technology, making them easy to install and very low maintenance.

## Features



Measures current (50Hz or 60Hz) every 30 seconds in three separate channels Measurement ranges:

- 0A-60A ( $\pm 0.1A$  and 2%)
- 0A-200A ( $\pm 0.2A$  and 2%)
- 0A-600A ( $\pm 0.5A$  and 2%)

Self-powered using ultra-low energy from the measured conductor, so there's no need for batteries or wiring



Simply clip around cables with no interruption to electrical supply



Transmit data wirelessly via LoRaWAN wireless protocol, which uses internationally approved, license-free ISM bands



## Dimensions (mm)

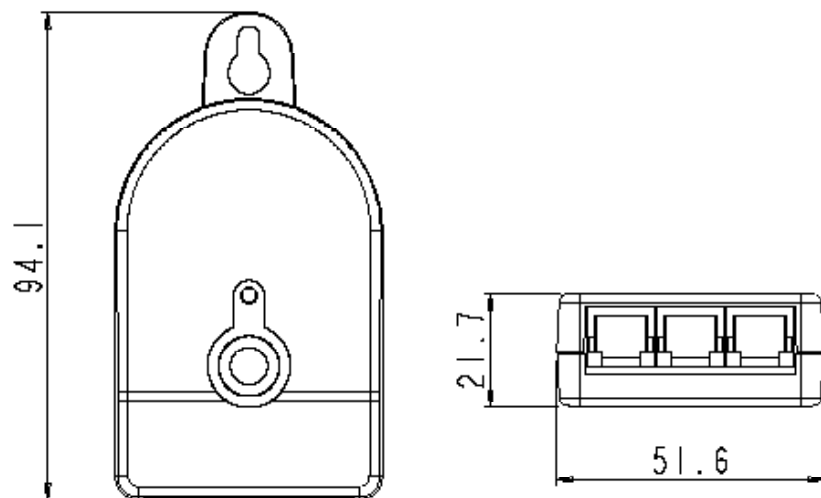

## Technical specification

Measurement	<p>Transmission rate: reports average of 6 measurements every 30s</p> <p>AC frequencies: 50Hz or 60Hz</p> <p>Sampling frequency: 22.6kHz</p> <p>Measurement range:</p> <ul style="list-style-type: none"> <li>• 0A-60A (<math>\pm 0.1A</math> and 2%)</li> <li>• 0A-200A (<math>\pm 0.2A</math> and 2%)</li> <li>• 0A-600A (<math>\pm 0.5A</math> and 2%)</li> </ul>
Power specification	<p>Power Source: Energy harvesting - powered by the measured conductor</p> <p>Minimum operating current:</p> <p>Low power mode: 1.25A - reports an average of 75 readings every 15m</p> <p>Standard operation: 1.5A - reports an average of 6 readings every 30s</p>
Wireless specification	<p>Protocol: LoRaWAN® Specification 1.0.4</p> <p>LoRaWAN® Device Class: Class A</p> <p>Radio frequency: EU868 (863-870 MHz), US915 (US902-928)</p> <p>Tx Power: +14 dBm (EU868, US915)</p> <p>Sensitivity: -146 dBm (EU868, US915)</p> <p>Security: LoRaWAN® End-to-End encryption (AES-CTR), Data Integrity Protection (AES-CMAC)</p> <p>Join Method: OTAA (Over-The-Air Activation)</p>
Enclosure specification	<p>Material: Nylon 66</p> <p>IP rating: IP4X</p> <p>Dimensions of transmitter: 80 x 55 x 20mm (approx)</p> <p>Dimensions of CT Clamps:</p> <ul style="list-style-type: none"> <li>• 60A: 25 x 22 x 35mm (approx)</li> <li>• 200A: 35 x 45 x 65mm (approx)</li> <li>• 600A: 65 x 41 x 85mm (approx)</li> </ul>
Installation	<p>Fixing: The clamp clips around the conductor.</p> <p>Diameter of measurable conductor:</p> <ul style="list-style-type: none"> <li>• 60A: 10mm or less</li> <li>• 200A: 24mm or less</li> <li>• 600A: 36mm or less</li> </ul> <p>Operating temperature and humidity range: -5°C to +40°C; 0% to 85%</p> <p>Storage temperature and humidity range: -20°C to +55°C; 0% to 85%</p> <p>Environment: indoor</p> <p>Calibration: not required</p>
Compliance	CE approved, RoHS compliant, WEE directive compliant, FCC compliant
Part number	CTLW_3CH_XXA_XXXX

